

Rychlovýměnné nožové držáky

ORIGINAL MULTISUISSE

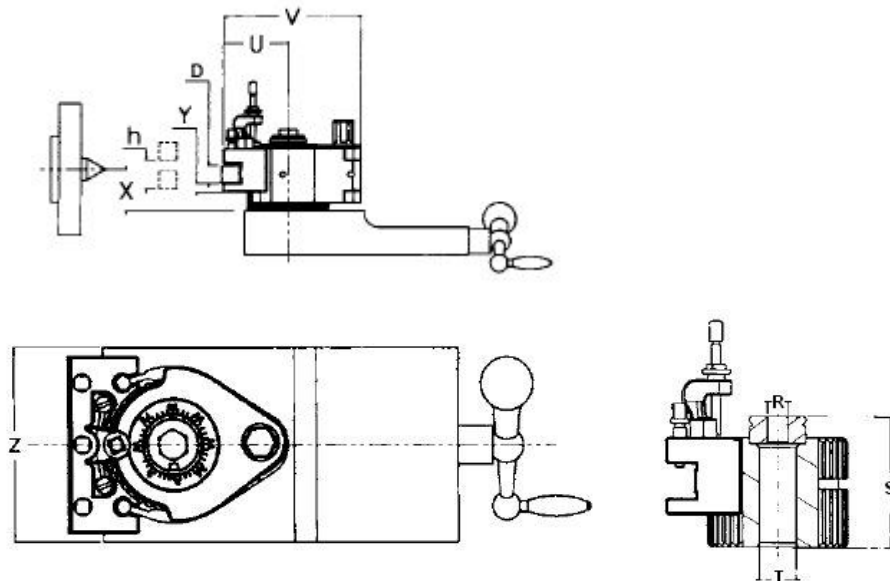

Hlava nožového držáku s excentrickým upínáním																
Velikost hlavy	Aa	A		E			B		C			D1			D2	
Max. výkon [kW]	1	2		4,5			7		13			20			28	
Max. výška soustr. nože D [mm]	12	16	20	16	20	25	25	32	32	40	45	40	50	63	50	63
Max. šířka saní Z [mm]	80	100		120			150		180			200			250	
Min. výška řezné hrany X [mm]	18	24,5	28,5	24,5	28,5	37	37	45,5	47	55	63	60	70	83	70	88
Celková šířka V [mm]	70	100		125			150		200			230	234	242	275	282
Celková výška S [mm]	37	56		68			79		110			122			135	
Max. vyložení U [mm]	30	48		60			71		90			112	116	124	140	147
Průměr otvoru hlavy T [mm]	13	20		20			32		40			40			80	

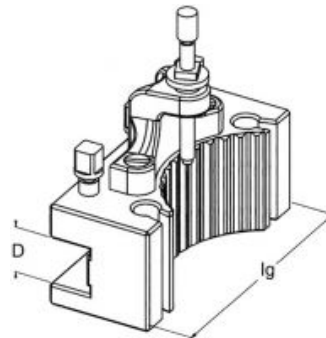

D – nožový držák

Velikost hlavy-typ držáku x D x lg [mm]

AaD - 12 x 50	ED - 20 x 100	CD - 32 x 150	D1D - 50 x 180
AD - 16 x 75	ED - 25 x 100	CD - 32 x 170	D1D - 63 x 180
AD - 16 x 90	BD - 25 x 120	CD - 40 x 150	D2D - 50 x 220
AD - 20 x 75	BD - 25 x 140	CD - 40 x 170	D2D - 63 x 220
AD - 20 x 90	BD - 32 x 120	CD - 45 x 170	
ED - 16 x 100	BD - 32 x 140	D1D - 40 x 180	

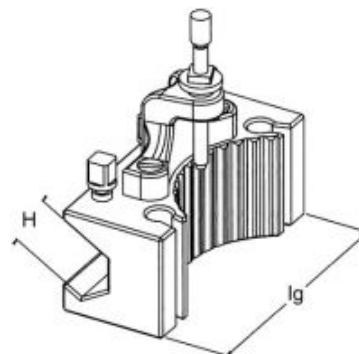

H – držák vyvrtávacího nože s prizmatem

Velikost hlavy-typ držáku x H x lg [mm]

AaH - 12 x 50	EH - 25 x 100	CH - 50 x 160	
AH - 20 x 85	BH - 30 x 130	D1H - 63 x 180	
EH - 16 x 100	CH - 40 x 160	D2H - 70 x 220	

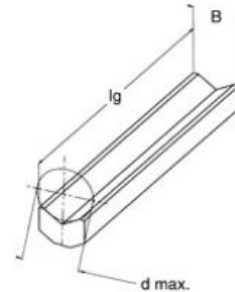

P – vkládací prizma pro držák vyvrtávacího nože H		
Velikost hlavy-typ držáku x d x lg [mm]	B [mm]	pro držák
AP - 14 x 85	16	AH - 20 x 85
EP - 16 x 100	20	EH - 16 x 100
BP - 20 x 130	22	BH - 32 x 130
CP - 25 x 160	30	CH - 40 x 160
CP - 32 x 160	33	CH - 50 x 160
D1P - 40 x 180	50	D1H - 63 x 180
D2P - 45 x 220	60	D2H - 70 x 220

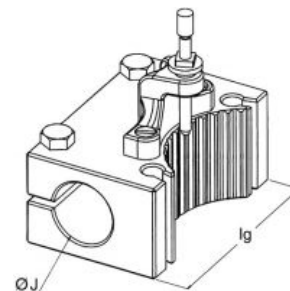

J – držák s válcovým otvorem			
Velikost hlavy-typ držáku x J x lg [mm]			
AaJ - 15 x 50	EJ - 40 x 100	CJ - 50 x 160	
AJ - 30 x 80	BJ - 40 x 120	D1J - 63 x 180	
EJ - 30 x 100	CJ - 40 x 160	D2J - 63 x 220	

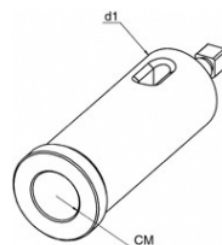

L – pouzdro s Morse kuželem pro nožový držák s válcovým otvorem J	
Velikost hlavy-typ držáku x MK (Morse kužel) x d1 [mm]	pro držák
AL/EL - 1 x 30	AJ - 30 , EJ - 30
AL/EL - 2 x 30	
EL/BL/CL - 1 x 40	EJ - 40 , BJ - 40 CJ - 40
EL/BL/CL - 2 x 40	
EL/BL/CL - 3 x 40	
EL/BL/CL - 4 x 40	
CL - 3 x 50	CJ - 50
CL - 4 x 50	
CL - 5 x 50	
DL1/DL2 - 5 x 63	D - 63

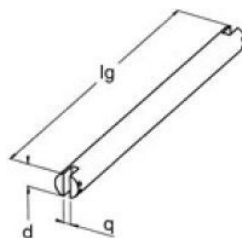

M – vyvrtávací tyč pro držák s válcovým otvorem J	
Velikost hlavy-typ držáku x d [mm] x lg [mm] x q [mm]	pro nůž T x e [mm]
AM/EM - 30 x 250 x 12	AJ - 30 , EJ - 30
EM/BM/CM - 40 x 500 x 12	EJ - 40 , BJ - 40 , CJ - 40
CM/D1M/D2M - 50 x 500 x 12	CJ - 50
D1M/D2M - 63 x 600 x 12	D - 63



T – držák upichovacího nože	
Velikost hlavy-typ držáku - upich. nůž	pro nůž
AaT - 2,5 x 10	AaTs - 2,5x10
AT-K - 2,7 x 10	AO-F - 2,7x10
ET-K - 2,4 x 15,9	AF/IIAF - 2,4x15,9
BT-K - 4 x 16	A1/2a - 4x16
CT-K - 4,8 x 25	A3a-H - 4,8x25

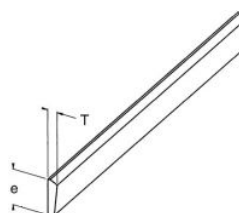

Upichovací nože	
Typ upich. nože	T x e [mm]
AaTs - 2,5 x 10	2,5x10
AO-F - 2,7 x 10	2,7x10
AF/IIAF - 2,4 x 15,9	2,4x15,9
A1/2a - 4 x 16	4x16
A3a-H - 4,8 x 25	4,8x25



FI – držák nože se zpětným pohybem pro vnitřní závit	
Velikost hlavy-typ držáku	pro \varnothing stopky nože [mm]
AFI	12
EFI	12
BFI	20
CFI	20



FE – držák nože se zpětným pohybem pro vnější závit	
Velikost hlavy-typ držáku	pro závitové nože
AFE	AF60°, AF55°
EFE	AF60°, AF55°
BFE	BF60°, BF55°
CFE	CF60°, CF55°

Polotovary
Polotovar A
Polotovar E
Polotovar B
Polotovar C
Polotovar D1
Polotovar D2

Náhradní díly
- na vyžádání