

90° DRILLING AND MILLING HEAD
TÊTE DE PERÇAGE - FRAISAGE A 90°

90° BOHR -UND FRAESKOPF
UNIDAD PARA FORAR - FRESAR A 90°

TESTA DI FORATURA - FRESATURA PER PINZE 90°

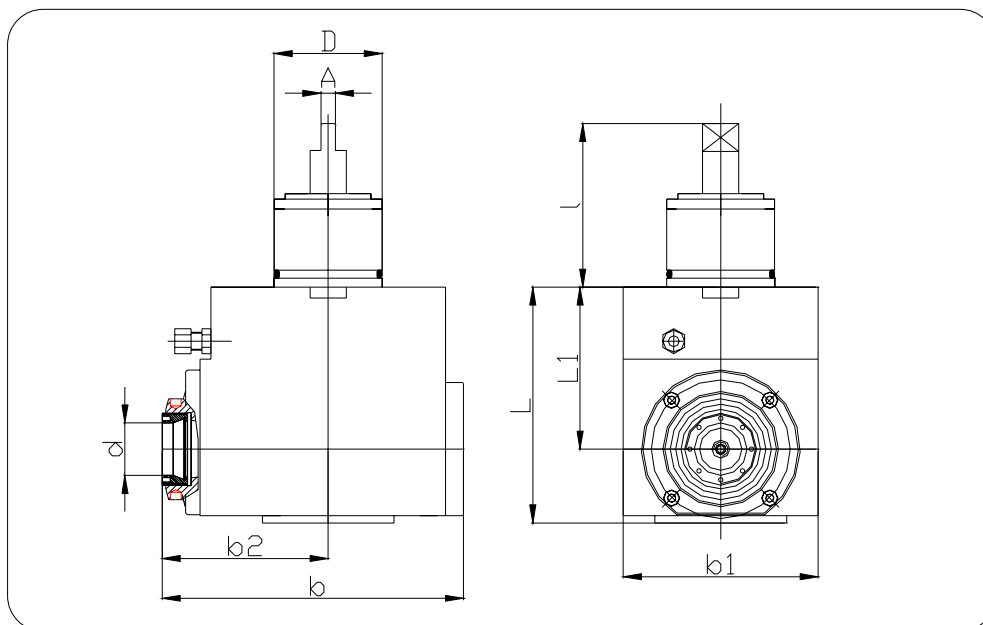

N. Cod.	D	d	A	l	L	L1	b	b1	b2	n. Max	n1/n2	Nm	Kg.
HE60MB20	60	4-20 ER 32	7,9	91	131	90	167	108	92	6000	1:1	50	14,000
HE60MB26	60	4-26 ER 40	7,9	91	131	90	182	108	107	6000	1:1	50	14,150

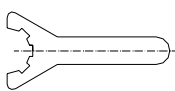
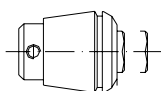

ACCESSORI
ACCESSORIES
ACCESSOIRES
ZUBEHÖR
ACCESORIOS