

90° DRILLING AND MILLING HEAD (2 SPINDLES) ER32

90° BOHR -UND FRAESKOPF (2 SPINDELN) ER32

TÊTE DE PERÇAGE - FRAISAGE A 90° (2 MANDRINS) ER32 UNIDAD PARA FORAR - FRESAR 90° (2 MANDRINOS) ER32

TESTA DI FORATURA - FRESATURA PER PINZE 90° (2 PORTAPINZE) ER32

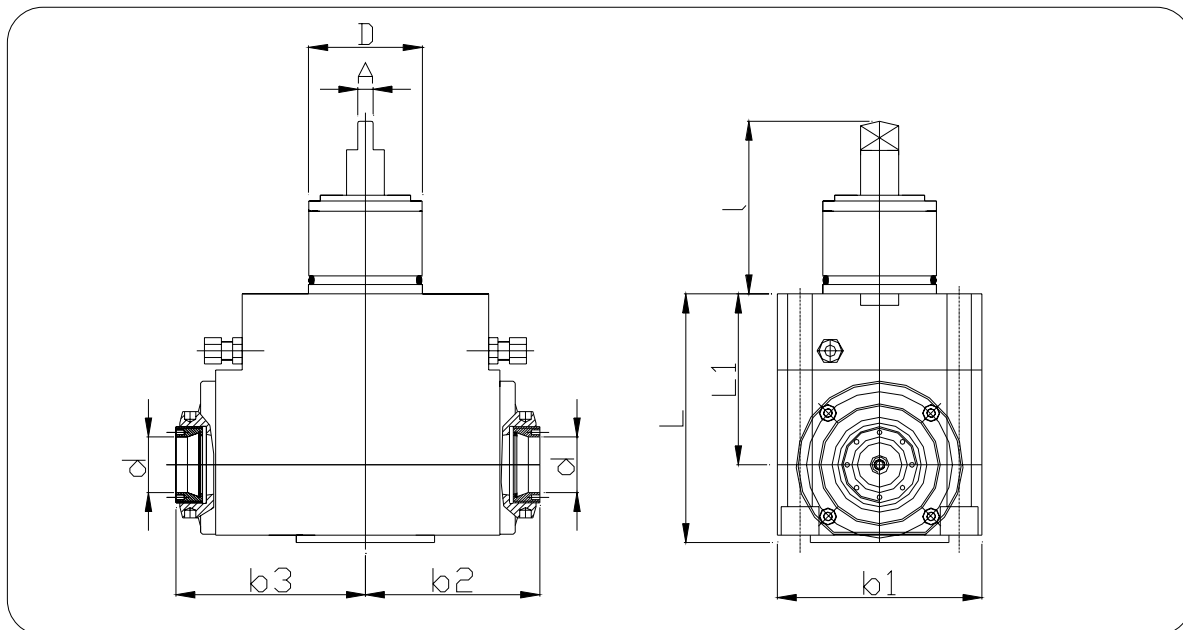

N. Cod.	D	d	A	l	L	L1	b1	b2	b3	n. Max	n1/n2	Nm	Kg.
HE60ML20	60	4-20 ER 32	7,9	91	131	90	108	92	100	6000	1:1	50	15,000
HE60ML26	60	4-26 ER 40	7,9	91	131	90	108	107	115	6000	1:1	50	15,150

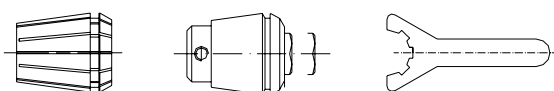

ACCESSORI
ACCESSORIES
ACCESSOIRES
ZUBEHÖR
ACCESORIOS