

0° DRILLING AND MILLING HEAD
TÊTE DE PERÇAGE - FRAISAGE 0°

0° BOHR -UND FRAESKOPF
UNIDAD PARA FORAR - FRESAR 0°

TESTADIFORATURA - FRESATURA (0°)

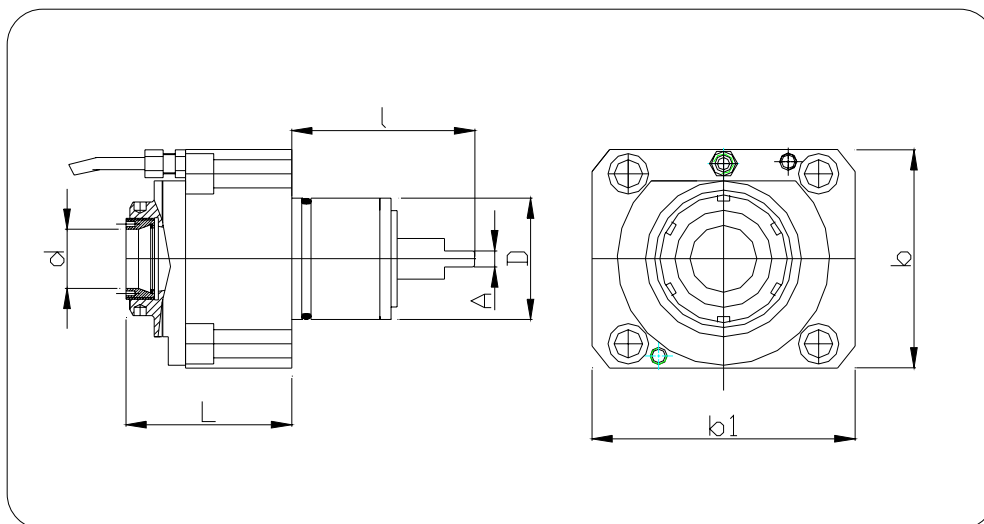

N. Cod.	D	d	A	l	L	b	b1	n. Max	n1/n2Nm	Kg.
HE60MA20	60	4-20 ER 32	7,9	91	82	108	130	6000	1:1 50	7,500
HE60MA26	60	4-26 ER 40	7,9	91	97	108	130	6000	1:1 50	7,650

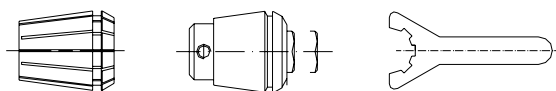

ACCESSORI
ACCESSORIES
ACCESSOIRES
ZUBEHÖR
ACCESORIOS