

90° DRILLING AND MILLING HEAD
TÊTE DE PERÇAGE - FRAISAGE A 90°

90° BOHR -UND FRAESKOPF
UNIDAD PARA FORAR - FRESAR A 90°

TESTA DI FORATURA - FRESATURA PER PINZE 90° -SINISTRO

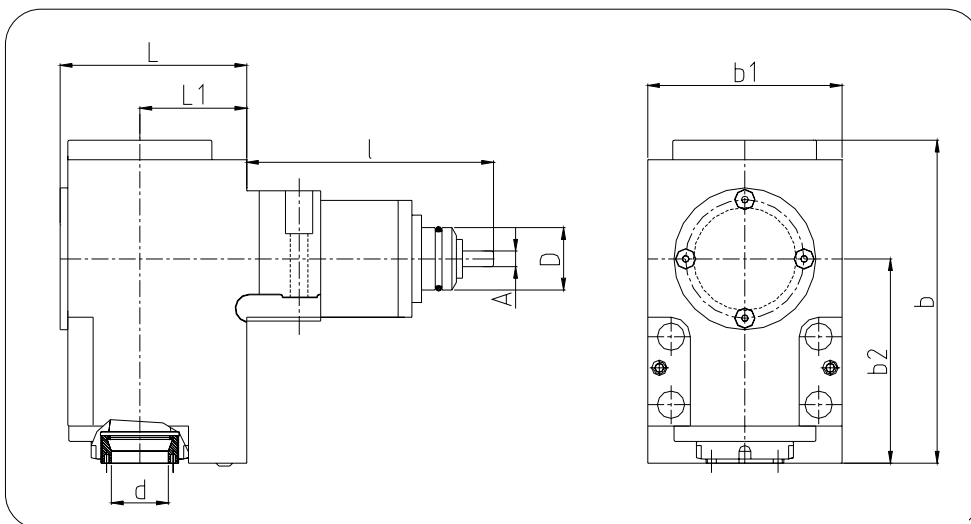

N. Cod.	Dh6	d	A	l	L	L1	b	b1	b2	n. Max	n1/n2	Nm	Kg.
HE32MB20S	32	4-20 ER 32	7,9	127	96	55	166	100	105	6000	1:1	50	12,000

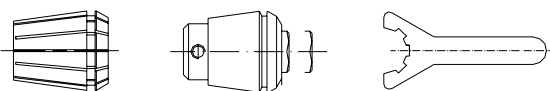
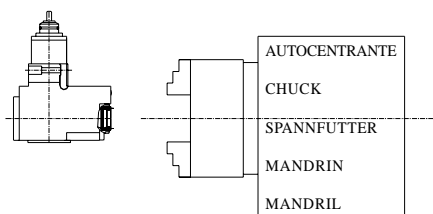

ACCESSORI
ACCESSORIES
ACCESSOIRES
ZUBEHÖR
ACCESORIOS