

0-90° DRILLING AND MILLING HEAD
TÊTE DE PERÇAGE - FRAISAGE 0-90°

0-90° BOHR -UND FRAESKOPF
UNIDAD PARA FORAR - FRESAR 0-90°

TESTADIFORATURA - FRESATURA ANGOLARE 0-90°

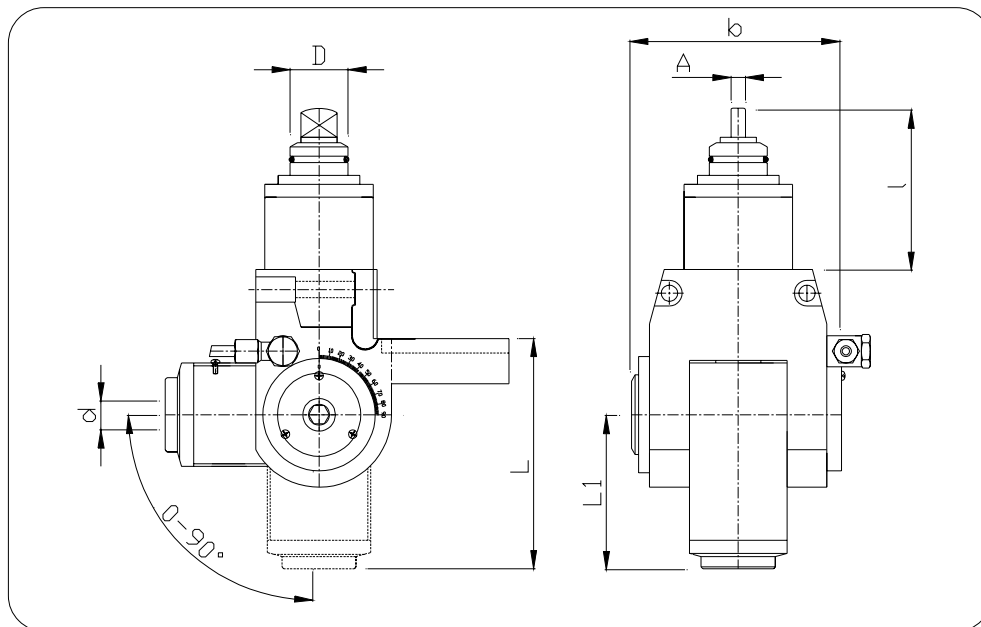

N. Cod.	Dh6	d	A	l	L	L1	b	n. Max	n1/n2	Nm	Kg.
HE32ME16	32	1-16 ER 25	7,9	127	130	85	116	6000	1:1	25	7,500

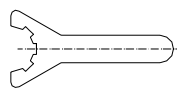
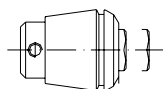
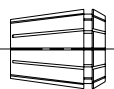

ACCESSORI
ACCESSORIES
ACCESSOIRES
ZUBEHÖR
ACCESORIOS