

0-90° DRILLING AND MILLING HEAD
TÊTE DE PERÇAGE - FRAISAGE 0-90°

0-90° BOHR -UND FRAESKOPF
UNIDAD PARA FORAR - FRESAR 0-90°

TESTA DI FORATURA - FRESATURA ANGOLARE 0-90°

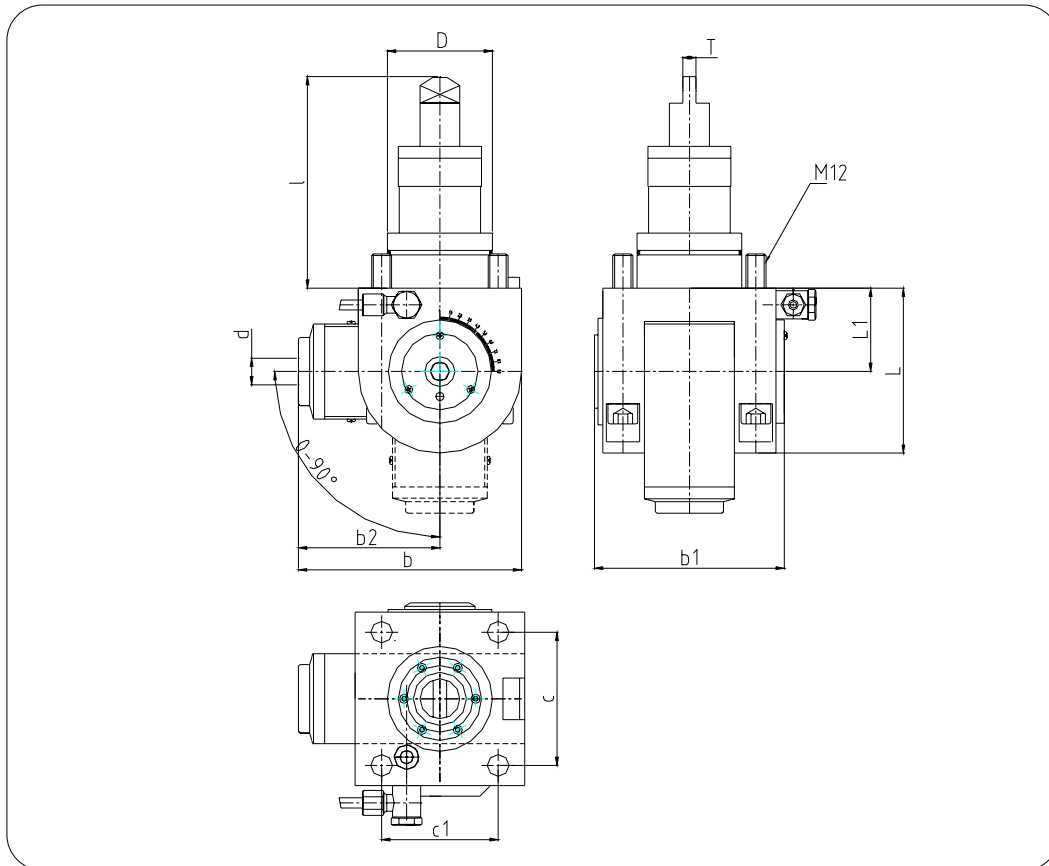

N. Cod.	Dh6	d	T	l	L	L1	b	b1	b2	C	C1	n. Max	n1/n2	Nm	Kg.
HE63GE16	63	3-16 ER25	8	127	99	50	134	114	85	80	70	6000	1:1	25	11,000

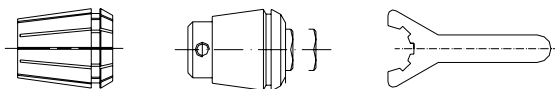

ACCESSORI
ACCESSORIES
ACCESSOIRES
ZUBEHÖR
ACCESORIOS