

90° DRILLING AND MILLING HEAD
TÊTE DE PERÇAGE - FRAISAGE A 90°

90° BOHR -UND FRAESKOPF
UNIDAD PARA FORAR - FRESAR A 90°

TESTA DI FORATURA - FRESATURA PER PINZE 90°

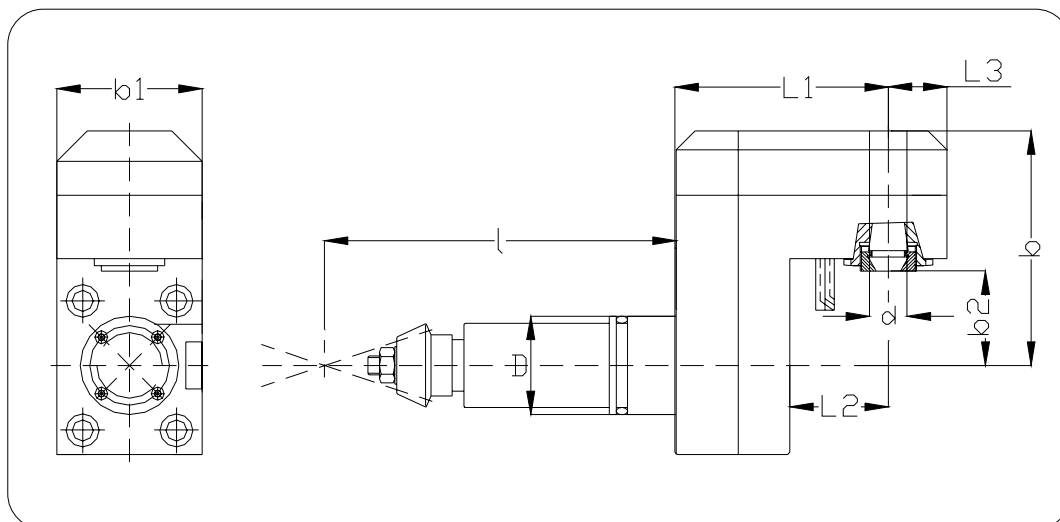

N. Cod.	Dh6	MACHINE	d	l	L1	L2	L3	b	b1	b2	n.Max	n1/n2	Nm	Kg.
TE42GD10	42	GLS150 - GTS150	1-10 ER16	150	91	42	25	100	62	38	4500	1x1	25	4,500

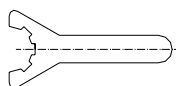

ACCESSORI
ACCESSORIES
ACCESSOIRES
ZUBEHÖR
ACCESORIOS