

0° DRILLING AND MILLING HEAD
TÊTE DE PERÇAGE - FRAISAGE A 0°

0° BOHR -UND FRAESKOPF
UNIDAD PARA FORAR - FRESAR A 0°

TESTADIFORATURA - FRESATURA PER PINZE 0°

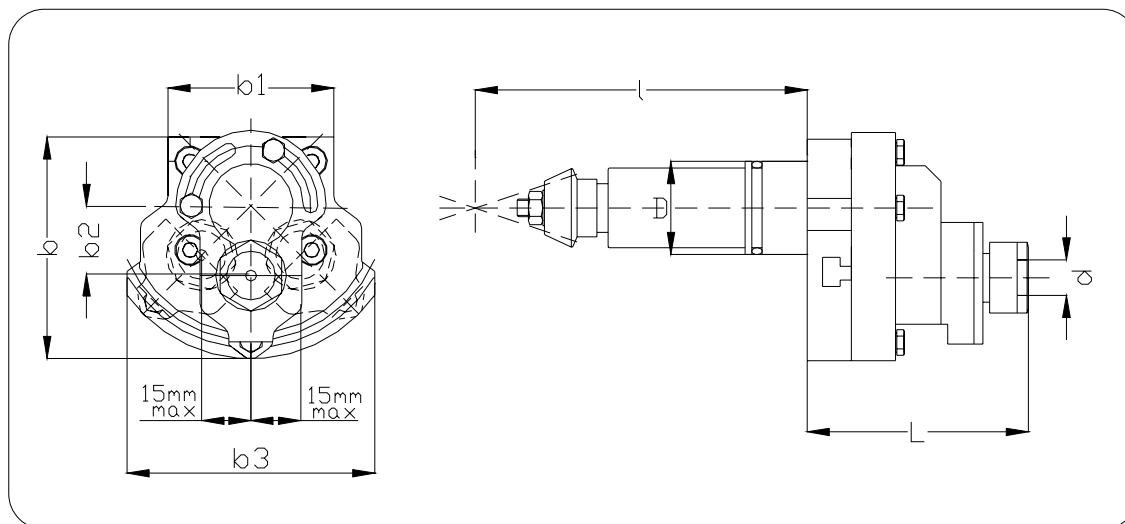

N. Cod.	Dh6	MACHINE	d	l	L	b	b1	b2	b3	n.Max	n1/n2	Nm	Kg.
TE42GH10	42	GLS150 - GTS150	1-10 ER16	150	100	100	75	32	112	4500	1x1	25	4,000

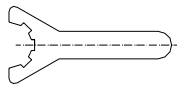

ACCESSORI
ACCESSORIES
ACCESSOIRES
ZUBEHÖR
ACCESORIOS