

0-90° DRILLING AND MILLING HEAD  
TÊTE DE PERÇAGE - FRAISAGE 0-90°

0-90° BOHR -UND FRAESKOPF  
UNIDAD PARA FORAR - FRESAR 0-90°

**TESTA DI FORATURA - FRESATURA ANGOLARE 0-90°**

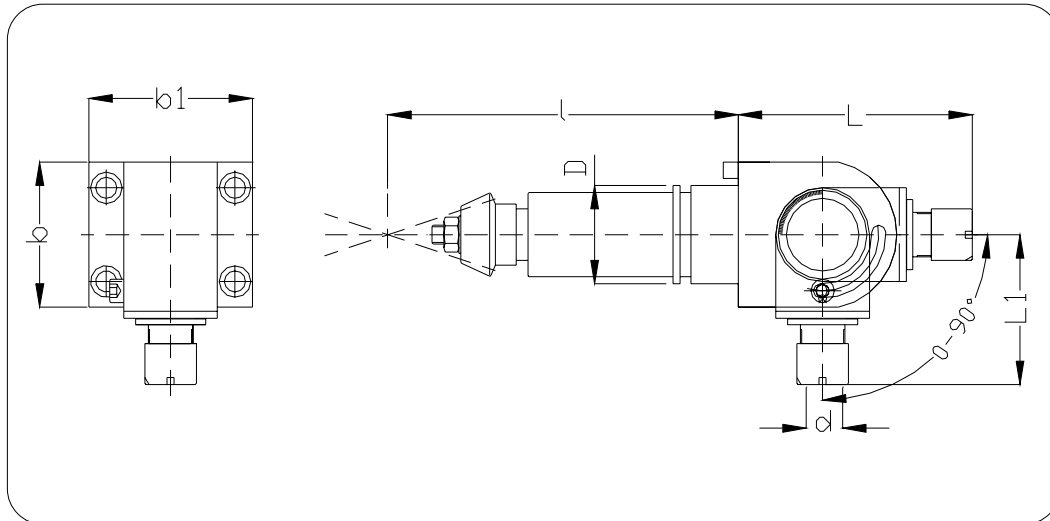

N. Cod.	Dh6	MACHINE	d	l	L	L1	b	b1	n. Max	n1/n2	Nm	Kg.
TE42GE10A	42	TS100	1-10 ER16	100	115	76	62	92	6000	1x1	25	4,050
TE42GE10	42	GLS150 - GTS150	1-10 ER16	150	115	76	62	92	6000	1x1	25	4,500
TE56GE10	56	GLS200-260 GTS200-260	1-10 ER16	200	115	76	85	98	6000	1x1	25	6,900

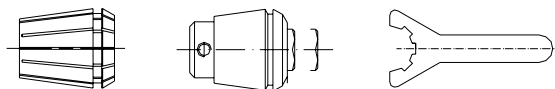

ACCESSORI  
ACCESSORIES  
ACCESSOIRES  
ZUBEHÖR  
ACCESORIOS