

0° DRILLING AND MILLING HEAD
TÊTE DE PERÇAGE - FRAISAGE 0°

0° BOHR -UND FRAESKOPF
UNIDAD PARA FORAR - FRESAR 0°

TESTA DI FORATURA - FRESATURA (0°)

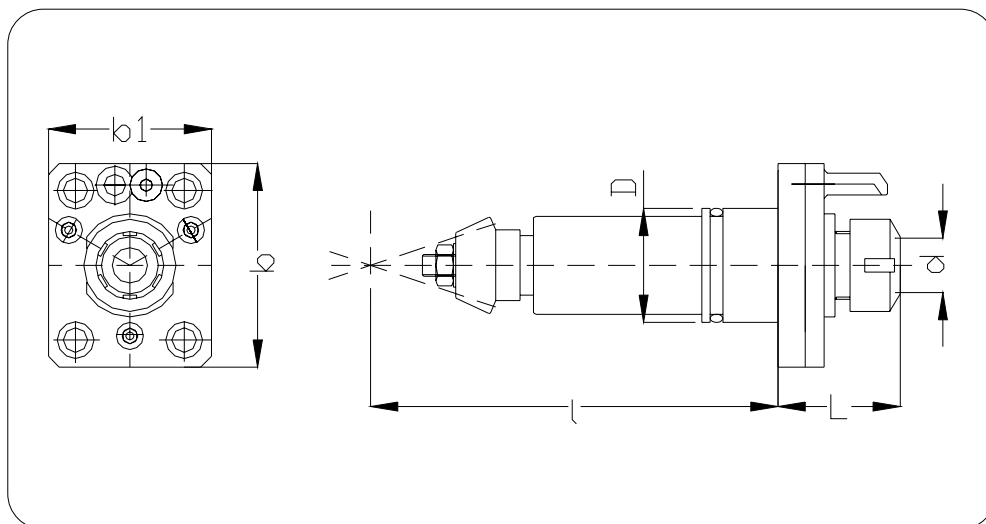

N. Cod.	Dh6	MACHINE	d	l	L	b	b1	n. Max	n1/n2	Nm	Kg.
TE42GA13A	42	TS100	1-13 ER 20	100	45	75	60	6000	1x1	25	2,050
TE42GA13	42	GLS150 - GTS150	1-13 ER 20	150	45	75	60	6000	1x1	25	2,500
TE56GA16	56	GLS200-260 GTS200-260	2-16 ER 25	200	52.5	100	85	6000	1x1	25	3,500

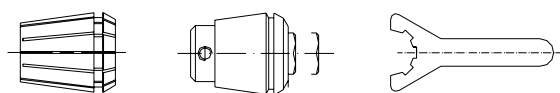

ACCESSORI
ACCESSORIES
ACCESSOIRES
ZUBEHÖR
ACCESORIOS