

90° DRILLING AND MILLING HEAD
TÊTE DE PERÇAGE - FRAISAGE A 90°

90° BOHR -UND FRAESKOPF
UNIDAD PARA FORAR - FRESAR A 90°

TESTA DI FORATURA - FRESATURA PER PINZE 90°

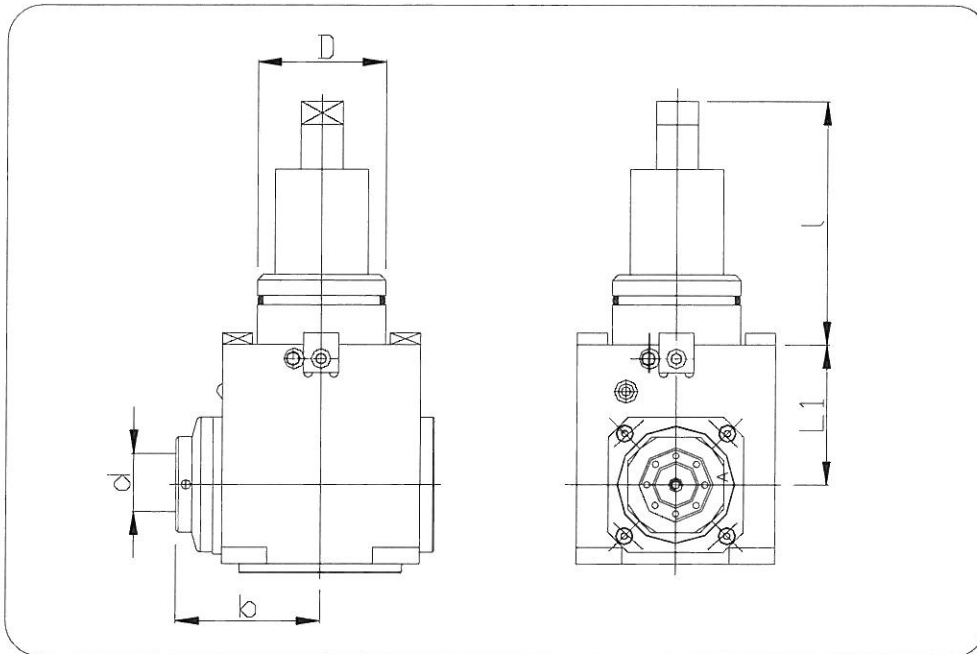

N. Cod.	D	d	l	L1	b	n. Max	n1/n2	Nm	Kg.
HE55DB16	55	2-16 ER25	104	60	62	6000	1:1	25	8,000
HE65DB20	65	4-20 ER32	112	72	85	6000	1:1	50	10,000
HE75DB26	75	4-26 ER40	110	60	112	6000	1:1	50	12,000

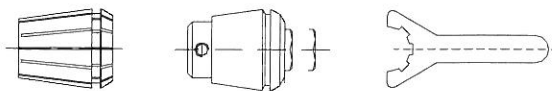

ACCESSORI
ACCESSORIES
ACCESSOIRES
ZUBEHÖR
ACCESORIOS