

0-90° DRILLING AND MILLING HEAD
TÊTE DE PERÇAGE - FRAISAGE 0-90°

0-90° BOHR -UND FRAESKOPF
UNIDAD PARA FORAR - FRESAR 0-90°

TESTA DI FORATURA - FRESATURA ANGOLARE 0-90°

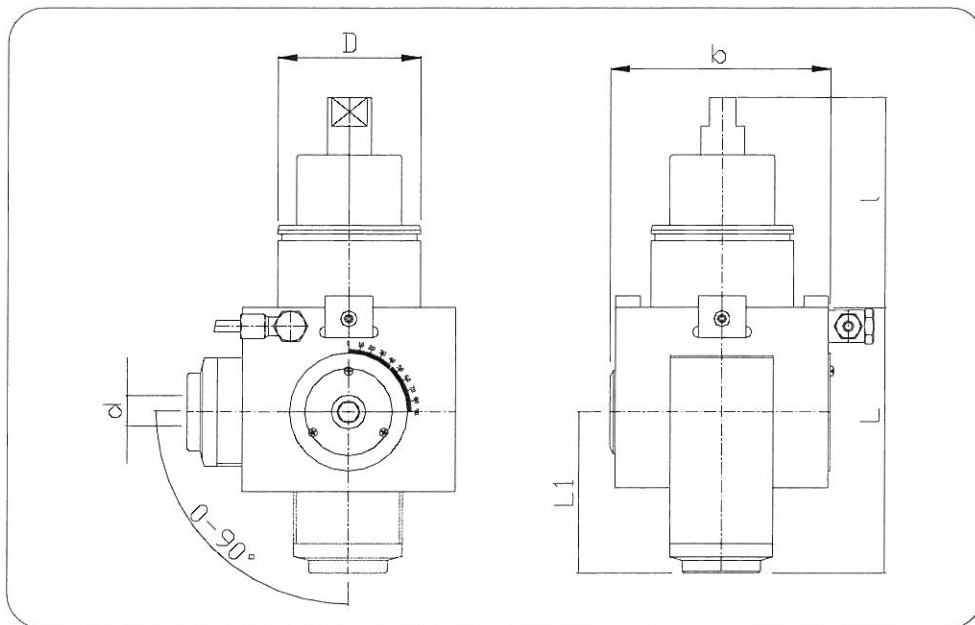

N. Cod.	D	d	l	L	L1	b	n. Max	n1/n2	Nm	Kg.
TE55DE10	55	1-10 ER16	104	115	76	92	6000	1:1	10	4,500
HE75DE16	75	1-16 ER25	110	140	85	116	6000	1:1	25	8,000

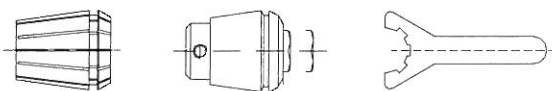

ACCESSORI
ACCESSORIES
ACCESSOIRES
ZUBEHÖR
ACCESORIOS