

0° DRILLING AND MILLING HEAD
TÊTE DE PERÇAGE - FRAISAGE 0°

0° BOHR -UND FRAESKOPF
UNIDAD PARA FORAR - FRESAR 0°

TESTA DI FORATURA - FRESATURA (0°)

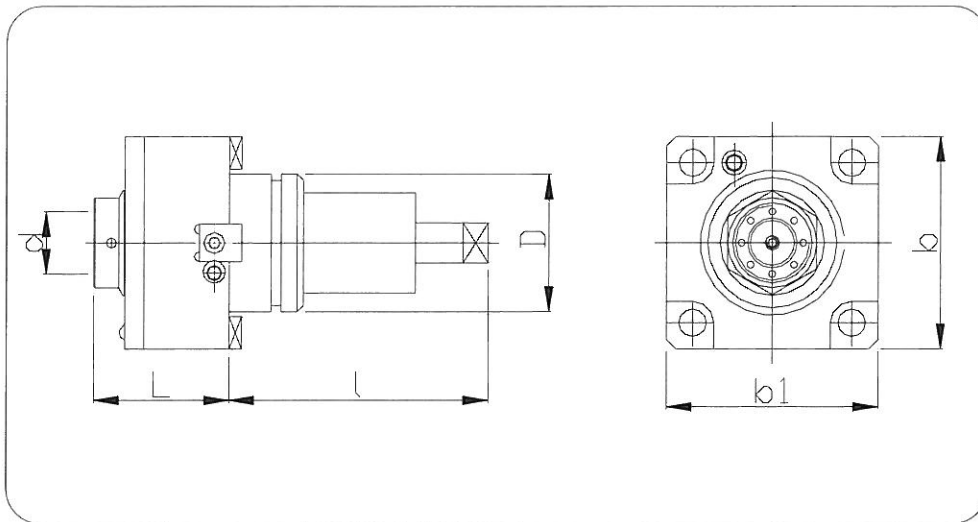

N. Cod.	D	d	l	L	b	b1	n. Max	n1/n2	Nm	Kg.
HE55DA16	55	2-16 ER25	104	54	85	85	6000	1:1	25	5,500
HE65DA20	65	4-20 ER32	112	61	94	94	6000	1:1	50	7,000
HE75DA26	75	4-26 ER40	110	75	112	112	6000	1:1	50	8,000

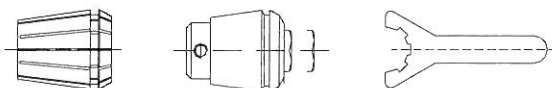

ACCESSORI
ACCESSORIES
ACCESSOIRES
ZUBEHÖR
ACCESORIOS